

Spindle bearings

With steel balls

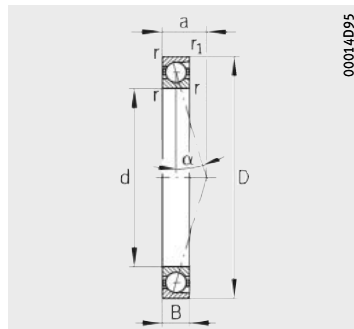

B719..-C, B70..-C, B72..-C
 $\alpha = 15^\circ$

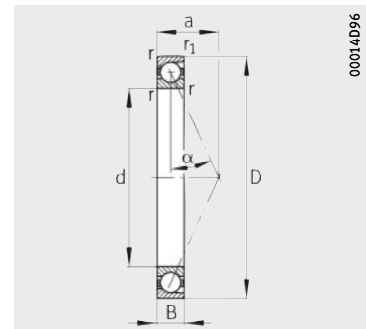

B719..-E, B70..-E, B72..-E
 $\alpha = 25^\circ$

Dimension table · Dimensions in mm							
Designation	Mass m ≈kg	Dimensions					
		d	D	B	r min.	r ₁ min.	a ≈
B7236-C-T-P4S	16,4	180	320	52	4	4	60
B7236-E-T-P4S	16,3	180	320	52	4	4	84
B7238-C-T-P4S	20	190	340	55	4	4	63
B7238-E-T-P4S	20	190	340	55	4	4	89
B7240-C-T-P4S	24,2	200	360	58	4	4	67
B7240-E-T-P4S	24,2	200	360	58	4	4	94
B7044-C-T-P4S	15,7	220	340	56	3	3	66
B7044-E-T-P4S	15,7	220	340	56	3	3	93
B7244-C-T-P4S	33,1	220	400	65	4	4	74
B7244-E-T-P4S	33,1	220	400	65	4	4	105
HCB71948-C-T-P4S ¹⁾	5,92	240	320	38	2,1	1,1	57
HCB71948-E-T-P4S ¹⁾	5,9	240	320	38	2,1	1,1	84
B71948-C-T-P4S	7,1	240	320	38	2,1	1,1	57
B71948-E-T-P4S	7,08	240	320	38	2,1	1,1	84
B7048-C-T-P4S	16,8	240	360	56	3	3	68
B7048-E-T-P4S	16,7	240	360	56	3	3	98
B71952-C-T-P4S	12	260	360	46	2,1	1,1	65
B71952-E-T-P4S	11,9	260	360	46	2,1	1,1	95
B71956-C-T-P4S	12,8	280	380	46	2,1	1,1	67
B71956-E-T-P4S	12,7	280	380	46	2,1	1,1	100
B71960-C-T-P4S	20,1	300	420	56	3	1,1	76
B71960-E-T-P4S	20	300	420	56	3	1,1	112
B71964-C-T-P4S	21,3	320	440	56	3	1,1	79
B71964-E-T-P4S	21,3	320	440	56	3	1,1	117
B71968-C-T-P4S	22,4	340	460	56	3	1,1	82
B71968-E-T-P4S	22,4	340	460	56	3	1,1	121
B71972-C-T-P4S	23,6	360	480	56	3	1,1	84
B71972-E-T-P4S	23,6	360	480	56	3	1,1	126
B71984-C-T-P4S	36,8	420	560	65	4	1,5	98
B71984-E-T-P4S	36,8	420	560	65	4	1,5	147
B71992-C-T-P4S	55,1	460	620	74	4	1,5	109
B71992-E-T-P4S	55	460	620	74	4	1,5	163
B719/500-C-T-P4S	67,9	500	670	78	5	2	117
B719/500-E-T-P4S	67,9	500	670	78	5	2	175

¹⁾ With ceramic balls.

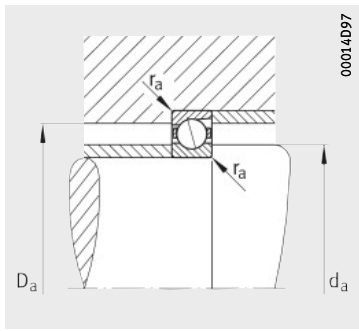

Mounting dimensions

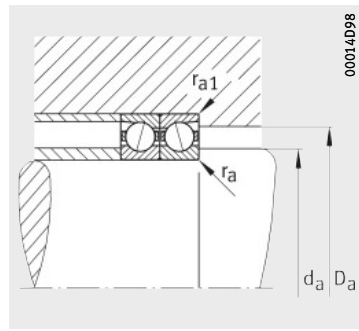

Mounting dimensions

Mounting dimensions				Basic load ratings		Fatigue limit load	Limiting speed	
d _a h12	D _a H12	r _a max.	r _{a1} max.	dyn. C _r kN	stat. C _{0r} kN	C _{ur} kN	n _G grease min ⁻¹	n _G oil min ⁻¹
213,5	286,5	3	3	305	390	17,6	3 800	5 600
213,5	286,5	3	3	290	365	16,8	3 400	5 000
223,5	306,5	3	3	315	415	18,3	3 400	5 000
223,5	306,5	3	3	300	390	17,4	3 200	4 800
238,5	321,5	3	3	325	440	19	3 200	4 800
238,5	321,5	3	3	310	415	18	3 000	4 500
239	321	2,5	1	325	440	19	3 200	4 800
239	321	2,5	1	310	415	18	3 000	4 500
264	356	3	3	400	560	23,2	2 800	4 300
264	356	3	3	380	540	22,1	2 600	4 000
254	307	1	1	154	215	9,6	4 000	6 000
254	307	1	1	145	200	9	3 600	5 300
254	307	1	1	224	310	13,5	3 200	4 800
254	307	1	1	212	285	12,8	3 000	4 500
260	341	2,5	1	335	465	19,5	3 000	4 500
260	341	2,5	1	315	440	18,5	2 800	4 300
278	342	2,1	1	285	415	17,1	2 800	4 300
278	342	2,1	1	270	390	16,2	2 600	4 000
298	362	2,1	1	300	450	18	2 600	4 000
298	362	2,1	1	280	425	17	2 400	3 800
322	398	1,5	1	360	570	21,8	2 400	3 800
322	398	1,5	1	340	540	20,7	2 200	3 600
342	418	1,5	1	375	620	23,1	2 200	3 600
342	418	1,5	1	355	585	21,9	2 000	3 400
362	438	1,5	1	380	640	23,6	2 200	3 600
362	438	1,5	1	360	610	17,9	1 900	3 200
382	458	1,5	1	390	695	24,8	2 000	3 400
382	458	1,5	1	375	640	23,4	1 800	3 000
444	536	1,5	1	510	980	32,5	1 700	2 800
444	536	1,5	1	475	915	30,5	1 500	2 400
493	587	1,5	1	530	1 080	34,5	1 500	2 400
493	587	1,5	1	500	1 000	32,5	1 400	2 200
538	632	2,5	1	550	1 160	36,5	1 400	2 200
538	632	2,5	1	520	1 080	34,5	1 200	1 900

